

48/3 = M14 - M33

Δ Per maschi di tipo corto.

Δ For taps short type.

Δ Für Gewindebohrer kurzer Ausführung.

Δ Pour tarauds type court.

Δ Para macho tipo corto.



Modello 48/3 Norma ANSI
Model 48/3 ANSI Standard
Modell 48/3 Norm ANSI
Modèle 48/3 Norme ANSI
Modelo 48/3 Estándar ANSI

CODICE CODE BESTELL NR CODE CÓDIGO	Maschio - Tap - Bohrer Taraud - Macho		
	Filetto Thread Gewinde Filet Rosca	f	□
48/3 4127	1/2"	9,32	6,99
48/3 4142	9/16"	10,9	8,18
48/3 4158	5/8"	12,19	9,14
Δ 48/3 4166C	3/8" NPT	17,78	13,49
48/3 4174	11/16"	13,77	10,31
48/3 4190	3/4"	14,99	11,23
48/3 4206	13/16"	16,56	12,42
Δ 48/3 4209C	1/2" NPT	17,46	13,08
48/3 4222	7/8"	17,7	13,28
48/3 4238	15/16"	19,3	14,48
48/3 4254	1"	20,32	15,24
Δ 48/3 4264C	3/4" NPT	23,01	17,25
48/3 4286	1-1/8"	22,76	17,07
48/3 4317	1-1/4"	25,93	19,46
Δ 48/3 4332C	1" NPT	28,57	21,41
48/3 4349	1-3/8" UNF	28,14	21,11

Modello 48/3 Norma ISO
Model 48/3 ISO Standard
Modell 48/3 Norm ISO
Modèle 48/3 Norme ISO
Modelo 48/3 Estándar ISO

CODICE CODE BESTELL NR CODE CÓDIGO	Maschio - Tap - Bohrer Taraud - Macho		
	Filetto Thread Gewinde Filet Rosca	f	□
48/3 14112	M14	11,2	9
48/3 16125	M16	12,5	10
48/3 1814112	M18	14	11,2
48/3 2014	M20	14	11,2
48/3 2216	M22	16	12,5
48/3 241814	M24	18	14
48/3 272016	M27	20	16
48/3 3020	M30	20	16
48/3 33224	M33	22,4	18



60/4 = M22 - M48

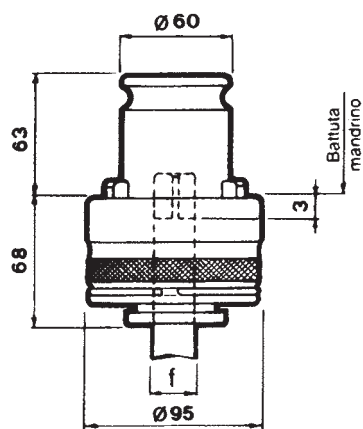

- * **Misure consigliate.**
- * *Mainly used sizes.*
- * Gängige Abmessungen.
- * *Dimensions conseillées.*
- * Principales medidas utilizadas.

- Δ **Per maschi di tipo corto.**
- Δ *For taps short type.*
- Δ Für Gewindebohrer kurzer Ausführung.
- Δ *Pour tarauds type court.*
- Δ Para macho tipo corto.

Modello 60/4 Norma DIN
 Model 60/4 DIN Standard
 Modell 60/4 Norm DIN
 Modèle 60/4 Norme DIN
 Modelo 60/4 Estándar DIN

CODICE CODE BESTELL NR CODE CÓDIGO	Maschio - Tap - Bohrer Taraud - Macho			
	Filetto Thread Gewinde Filet Rosca	f	□	DIN
60/4 2016	M20	16	12	376
60/4 2218*	M22	18	14,5	376
60/4 2418*	M24	18	14,5	376
60/4 2720*	M27	20	16	376
60/4 3022*	M30	22	18	376
60/4 3325*	M33	25	20	376
60/4 3628*	M36	28	22	376
60/4 3932*	M39	32	24	376
60/4 4232*	M42	32	24	376
60/4 4536*	M45	36	29	376
60/4 4836*	M48	36	29	376

Modello 60/4 Norma ANSI
 Model 60/4 ANSI Standard
 Modell 60/4 Norm ANSI
 Modèle 60/4 Norme ANSI
 Modelo 60/4 Estándar ANSI

CODICE CODE BESTELL NR CODE CÓDIGO	Maschio - Tap - Bohrer Taraud - Macho		
	Filetto Thread Gewinde Filet Rosca	f	□
Δ 60/4 4381C	1-1/2"	31,32	23,5
Δ 60/4 4412C	1-5/8"	33,15	24,87
Δ 60/4 4419C	1-1/4"NPT	33,34	24,99
Δ 60/4 4444C	1-3/4"	36,32	27,23
Δ 60/4 4476C	1-7/8"	38,58	28,93
Δ 60/4 4478C	1-1/2" NPT	38,1	28,57

BUSSOLE PER MASCHIARE CON FRIZIONE REGISTRABILE E FISSAGGIO MASCHIO CON GRANI ESTERNI

BUSH FOR TAPPING WITH ADJUSTABLE FRICTION CLUTCH TAP FIXED WITH EXTERNAL SCREWS
 SCHNELLWECHSELEINSÄTZE MIT SICHERHEITSKUPPLUNG GEWINDEBOHRER BEFESTIGUNG MIT SCHRAUBEN
 DOUILLE PORTE TARAUD AVEC EMBRAYAGE REGLABLE ET SERRAGE DU TARAUD AVEC DES VIS
 CASQUILLO PARA ROSCADO CON EMBRAGUE DE FRICCIÓN AJUSTABLE MACHO FIJADO CON TORNILLOS EXTERNOS

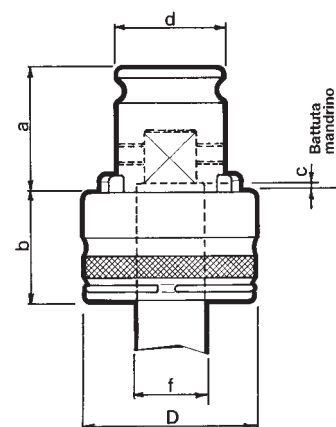

Modello 19/1 G - Model 19/1 G - Modell 19/1 G - Modèle 19/1 G - Modelo 19/1 G							
CODICE CODE BESTELL NR CODE CÓDIGO	d	D	a	b	c	Maschio - Tap - Bohrer Taraud - Macho	
						f	□
19/1G 129	19	32	21,5	23	2,5	12	9
19/1G 4158	19	32	21,5	23	2,5	12, 19	9, 14

Modello 31/2 G - Model 31/2 G - Modell 31/2 G - Modèle 31/2 G - Modelo 31/2 G							
CODICE CODE BESTELL NR CODE CÓDIGO	d	D	a	b	c	Maschio - Tap - Bohrer Taraud - Macho	
						f	□
31/2G 2016	31	50	35	29	2	20	16
31/2G 2218	31	50	35	29	2	22	18
31/2G 4238	31	50	35	29	2	19,3	14,48

Modello 48/3 G - Model 48/3 G - Modell 48/3 G - Modèle 48/3 G - Modelo 48/3 G							
CODICE CODE BESTELL NR CODE CÓDIGO	d	D	a	b	c	Maschio - Tap - Bohrer Taraud - Macho	
						f	□
48/3G 3224	48	72	55,5	39	0	32	24
48/3G 3629	48	72	55,5	39	0	36	29

Modello 60/4 G - Model 60/4 G - Modell 60/4 G - Modèle 60/4 G - Modelo 60/4 G							
CODICE CODE BESTELL NR CODE CÓDIGO	d	D	a	b	c	Maschio - Tap - Bohrer Taraud - Macho	
						f	□
60/4G 0521	60	95	63	60	-7	40	32
60/4G 4508	60	95	63	60	-7	41,76	31,32

Per lavorazioni leggere
 Suitable for light machining
 Für Leichtmetallbearbeitung
 Apte pour usinage léger

BUSSOLE MODULARI PROLUNGATE PER MASCHIARE CON FRIZIONE REGISTRABILE

BUSH FOR TAPPING WITH SAFETY FRICTION CLUTCH EXTENDED
SCHNELLWECHSELEINSÄTZE MIT SICHERHEITSKUPPLUNG UND LANGE AUSFUHRUNG
DOUILLE PORTE TARAUD MODULAIRE PROLONGÉE AVEC EMBRAYAGE REGLABLE
CASQUILLO PARA ROSCADO CON EMBRAGUE DE FRICCIÓN DE SEGURIDAD EXTENDIDO

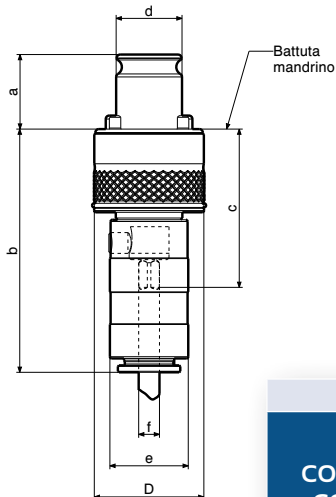

Modello 19/1 P - Model 19/1 P - Modell 19/1 P - Modèle 19/1 P - Modelo 19/1 P

CODICE CODE BESTELL NR CODE CÓDIGO	Bussola + Terminale Bush + Terminal Einsatz + Terminal Douille + Terminal Casquillo + Terminal	Dimensioni - Dimensions Abmessungen Dimensions - Dimensión						Maschio - Tap Bohrer Taraud - Macho		
		d	D	a	b	c	e	Filetto Thread Filet Rosca	f	□
19/1P 335 =	42146/0030 + 42147/0030	19	32	21.5	70	51	23	M3	3.5	2.7
19/1P 445 =	42146/0040 + 42147/0040	19	32	21.5	70	51	23	M4	4.5	3.4
19/1P 56 =	42146/0050 + 42147/0050	19	32	21.5	70	51	23	M5	6	4.9
19/1P 6649 =	42146/0060 + 42147/0050	19	32	21.5	70	51	23	M6	6	4.9
19/1P 88 =	42146/0080 + 42147/0080	19	32	21.5	70	51	23	M8	8	6.2
19/1P 107 =	42146/0100 + 42147/0101	19	32	21.5	70	51	23	M10	7	5.5
19/1P 1010 =	42146/0100 + 42147/0100	19	32	21.5	70	51	23	M10	10	8
19/1P 129 =	42146/0120 + 42147/0120	19	32	21.5	70	51	23	M12	9	7

Modello 31/2 P - Model 31/2 P - Modell 31/2 P - Modèle 31/2 P - Modelo 31/2 P

CODICE CODE BESTELL NR CODE CÓDIGO	Bussola + Terminale Bush + Terminal Einsatz + Terminal Douille + Terminal Casquillo + Terminal	Dimensioni - Dimensions Abmessungen Dimensions - Dimensión						Maschio - Tap Bohrer Taraud - Macho		
		d	D	a	b	c	e	Filetto Thread Filet Rosca	f	□
31/2P 6649 =	42246/0060 + 42247/0060	31	50	35	96	67	34.5	M6	6	4.9
31/2P 88 =	42246/0080 + 42247/0080	31	50	35	96	67	34.5	M8	8	6.2
31/2P 107 =	42246/0100 + 42247/0101	31	50	35	96	67	34.5	M10	7	5.5
31/2P 1010 =	42246/0100 + 42247/0100	31	50	35	96	67	34.5	M10	10	8
31/2P 129 =	42246/0120 + 42247/0120	31	50	35	96	67	34.5	M12	9	7
31/2P 1411 =	42246/0140 + 42247/0140	31	50	35	96	67	34.5	M14	11	9
31/2P 1612 =	42246/0160 + 42247/0160	31	50	35	96	67	34.5	M16	12	9
31/2P 181411 =	42246/0180 + 42247/0180	31	50	35	96	67	34.5	M18	14	11
31/2P 2016 =	42246/0200 + 42247/0200	31	50	35	96	67	34.5	M20	16	12

BUSSOLE MODULARI PROLUNGATE PER MASCHIARE CON FRIZIONE REGISTRABILE

BUSH FOR TAPPING WITH SAFETY FRICTION CLUTCH EXTENDED

SCHNELLWECHSELEINSÄTZE MIT SICHERHEITSKUPPLUNG UND LANGE AUSFÜHRUNG

DOUILLE PORTE TARAUD MODULAIRE PROLONGÉE AVEC EMBRAYAGE REGLABLE

CASQUILLO PARA ROSCADO CON EMBRAGUE DE FRICCIÓN DE SEGURIDAD EXTENDIDO

Modello 48/3 P - Model 48/3 P - Modell 48/3 P - Modèle 48/3 P - Modelo 48/3 P										
CODICE CODE BESTELL NR CODE CÓDIGO	Bussola + Terminale Bush + Terminal Einsatz + Terminal Douille + Terminal Casquillo + Terminal	Dimensioni - Dimensions Abmessungen Dimensiones - Dimensión						Maschio - Tap Bohrer Taraud - Macho		
		d	D	a	b	c	e	Filetto Thread Gewinde Filet Rosca	f	□
48/3P 1411 =	42346/0140 + 42347/0140	48	72	55,5	132	89	48	M14	11	9
48/3P 1612 =	42346/0160 + 42347/0160	48	72	55,5	132	89	48	M16	12	9
48/3P 181411 =	42346/0180 + 42347/0180	48	72	55,5	132	89	48	M18	14	11
48/3P 2016 =	42346/0200 + 42347/0200	48	72	55,5	132	89	48	M20	16	12
48/3P 2218 =	42346/0220 + 42347/0220	48	72	55,5	132	89	48	M22	18	14,5
48/3P 2418145 =	42346/0240 + 42347/0220	48	72	55,5	132	89	48	M24	18	14,5
48/3P 2720 =	42346/0270 + 42347/0270	48	72	55,5	132	89	48	M27	20	16
48/3P 3022 =	42346/0300 + 42347/0300	48	72	55,5	132	89	48	M30	22	18
48/3P 3325 =	42346/0330 + 42347/0330	48	72	55,5	132	89	48	M33	25	20

PROLUNGHE

EXTENSION

VERLÄNGERUNGEN

EXTENSION

EXTENSIÓN

CODICE CODE BESTELL NR CODE CÓDIGO	Per Bussola For Bush Einsatz Pour douille Para casquillo	D	L
42150/25	19/1P-19/11P	23	25
42150/50	19/1P-19/11P	23	50
42250/50	31/2P-31/12P	35	50
42250/100	31/2P-31/12P	35	100
42350/50	48/3P-48/13P	48	50
42350/100	48/3P-48/13P	48	100

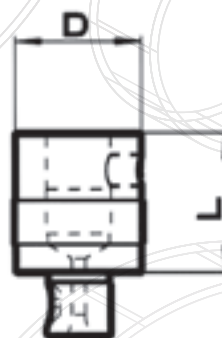

ESEMPIO DI COMPOSIZIONE PER BUSSOLE PROLUNGATE

EXAMPLE TO USE EXTENDED BUSHES
KOMBINATION VON LANGEN SCHNELLWECHSELEINSÄTZE UND VERLÄNGERUNGEN
EXEMPLE DE COMPOSITION DE DOUILLE MODULAIRE PROLONGÉE
EJEMPLO DE USO DE CASQUILLOS EXTENDIDOS

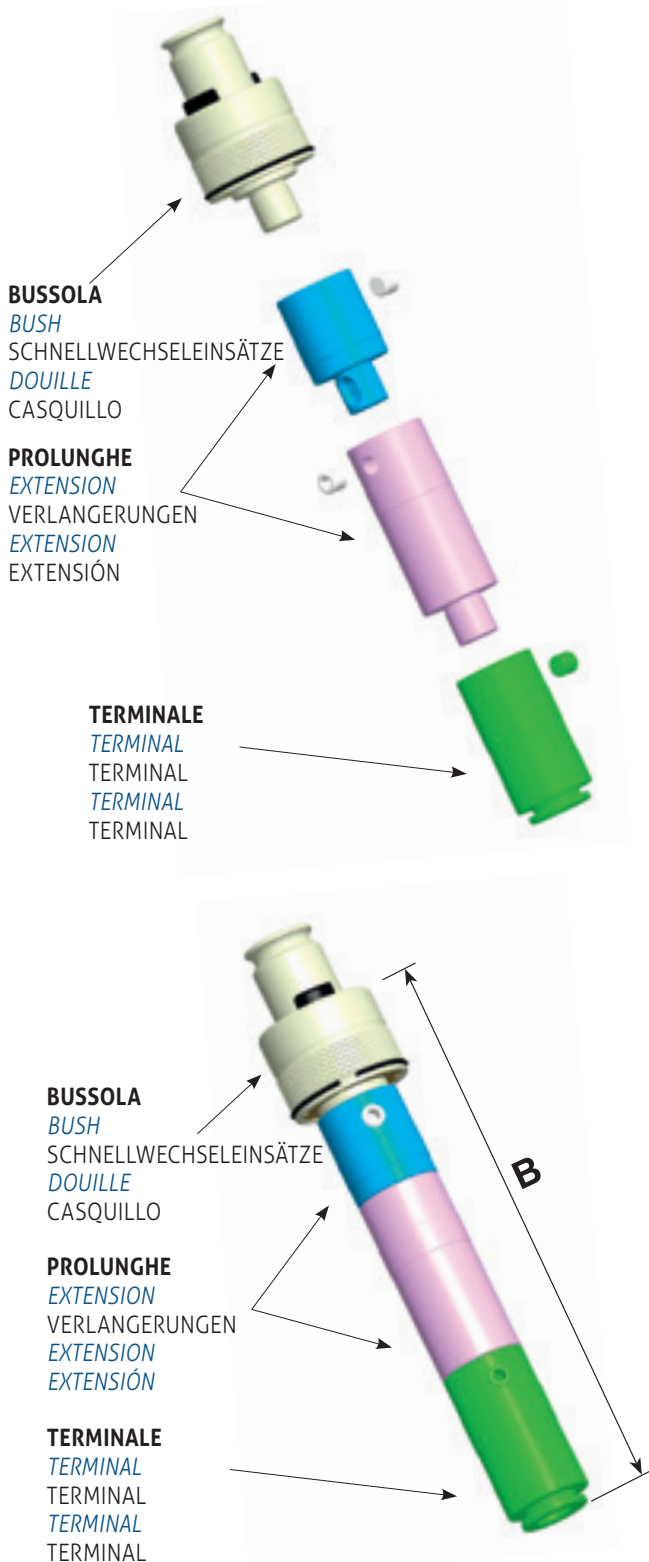

In questa pagina descriviamo un esempio pratico di come si possono comporre le bussole modulari prolungate 19/1P - 19/11P - 31/2P - 31/12P - 48/3P - 48/13P descritte nelle tabelle delle pagine precedenti.

Per esempio:

inserendo in una bussola con codice 19/1P-335 una prolunga cod. 42150/25 di lunghezza 25 mm. ed una prolunga cod. 42150/50 di lunghezza 50 mm si ottiene una lunghezza utile "B" di 145 mm. ($70+25+50=145$). Quindi dall'esempio succitato si può dedurre che è possibile ottenere per le bussole modulari prolungate una lunghezza minima di 70 mm, incrementabile con passi di 25 mm.

On this page we explain a practice example for our extended bushes 19/1P - 19/11P - 31/2P - 31/12P - 48/3P - 48/13P.

For example:

as the length of 19/1P is 70 mm, if you join an extension 42150/25 (L=25 mm) and an extension 42150/50 (L=50 mm) you can obtain the total length "B" of mm 145. Available of 25 mm. extension.

Auf dieser Seite zeigen wir Ihnen ein praktisches Beispiel für unsere langen Schnellwechseleinsätze 19/1P - 19/11P - 31/2P - 31/12P - 48/3P - 48/13P auf.

Beispiel:

Die Auskraglänge des Schnellwechseleinsatzes 19/1P ist 70 mm. Wenn Sie eine Verlängerung 42150/25 (L=25 mm) und eine Verlängerung 42150/50 (L=50 mm) einbringen erhalten Sie als Gesamtauskraglänge „B“ 145 mm weitere 25mm verfügbar verlängerungen

Dans cette page on vous propose un exemple pratique de composition de douille modulaire prolongée 19/1P - 19/11P - 31/2P - 31/12P - 48/3P - 48/13P décrites dans les pages précédentes :

Par exemple :

Dans une douille code 19/1P 335 on met une extension code 42150/25 avec une longueur de 25 mm. plus une extension code 42150/50 avec une longueur de 50 mm. et on obtient une longueur totale 'B' de 145 mm. ($70+25+50=145$).

Donc sur la base de cet exemple, il est possible déduire que l'on peut obtenir une douille modulaire prolongée avec une longueur minimum de 70 mm, réalisée avec des multiples de 25 mm.

En esta página le mostramos un ejemplo práctico para nuestros casquillos extendidos 19/1P - 19/11P - 31/2P - 31/12P - 48/3P - 48/13P.

Por ejemplo:

Si a la longitud de 19/1P es 70 mm., se le une una extensión 42150/50 (L=50 mm.) se puede obtener una longitud total «B» de 145 mm.. La longitud se puede aumentar de 25 a 25 mm.

RICAMBI

SPARE PARTS
ERSATZTEILE
PIÈCES DE RECHANGE
PIEZAS DE RECAMBIO

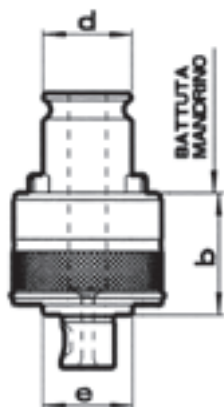

MOD. 42146 Bussola Bush Einsatz Douille Casquillo		MOD. 42147 Terminale Terminal Terminal Terminal			
d	19	e	23		
b	26	L	44		
e	23	L1	25		
CODICE CODE BESTELL NR CODE CÓDIGO	Filetto Thread Gewinde Filet Rosca	CODICE CODE BESTELL NR CODE CÓDIGO	Filetto Thread Gewinde Filet Rosca	f	□
42146/0030	M3	42147/0030	M3	3.5	2.7
42146/0040	M4	42147/0040	M4	4.5	3.4
42146/0050	M5	42147/0050	M5	6	4.9
42146/0060	M6	42147/0050	M6	6	4.9
42146/0080	M8	42147/0080	M8	8	6.2
42146/0100	M10	42147/0101	M10	7	5.5
42146/0100	M10	42147/0100	M10	10	8
42146/0120	M12	42147/0120	M12	9	7



MOD. 42246 Bussola Bush Einsatz Douille Casquillo		MOD. 42247 Terminale Terminal Terminal Terminal Terminal			
d	31	e	34.5		
b	33	L	63		
e	34.5	L1	34		
CODICE CODE BESTELL NR CODE CÓDIGO	Filetto Thread Gewinde Filet Rosca	CODICE CODE BESTELL NR CODE CÓDIGO	Filetto Thread Gewinde Filet Rosca	f	□
42246/0060	M6	42247/0060	M6	6	4.9
42246/0080	M8	42247/0080	M8	8	6.2
42246/0100	M10	42247/0101	M10	7	5.5
42246/0100	M10	42247/0100	M10	10	8
42246/0120	M12	42247/0120	M12	9	7
42246/0140	M14	42247/0140	M14	11	9
42246/0160	M16	42247/0160	M16	12	9
42246/0180	M18	42247/0180	M18	14	11
42246/0200	M20	42247/0200	M20	16	12

MOD. 42346 Bussola Bush Einsatz Douille Casquillo		MOD. 42347 Terminale Terminal Terminal Terminal Terminal			
d	48	e	48		
b	44	L	88		
e	48	L1	45		
CODICE CODE BESTELL NR CODE CÓDIGO	Filetto Thread Gewinde Filet Rosca	CODICE CODE BESTELL NR CODE CÓDIGO	Filetto Thread Gewinde Filet Rosca	f	□
42346/0140	M14	42347/0140	M14	11	9
42346/0160	M16	42347/0160	M16	12	9
42346/0180	M18	42347/0180	M18	14	11
42346/0200	M20	42347/0200	M20	16	12
42346/0220	M22	42347/0220	M22	18	14.5
42346/0240	M24	42347/0220	M24	18	14.5
42346/0270	M27	42347/0270	M27	20	16
42346/0300	M30	42347/0300	M30	22	18
42346/0330	M33	42347/0330	M33	25	20

BUSSOLA PER MASCHIARE SENZA FRIZIONE REGISTRABILE

BUSH FOR TAPPING WITHOUT SAFETY FRICTION CLUTCH
SCHNELLWECHSELEINSAETZE OHNE SICHERHEITSKUPPLUNG

DOUILLES PORTE TARAUD SANS EMBRAYAGE REGLABLE

CASQUILLO PARA ROSCADO SIN EMBRAGUE DE FRICCIÓN DE SEGURIDAD

13/10= M2-M10



Modello 13/10 Norma DIN
Model 13/10 DIN Standard
Modell 13/10 Norm DIN
Modèle 13/10 Norme DIN
Modelo 13/10 Estándar DIN

CODICE CODE BESTELL NR CODE CÓDIGO	Maschio - Tap Bohrer Taraud - Macho		
	f	□	DIN
13/10 2521	2,5	2,1	371
13/10 2821	2,8	2,1	371
13/10 3527	3,5	2,7	371
13/10 4534	4,5	3,4	371
13/10 5543	5,5	4,3	376
13/10 649	6	4,9	371
13/10 755	7	5,5	376
13/10 43	4	3	371
13/10 0081 *	8	6,2	371

- * Le misure non sono come quelle indicate nel disegno
- * The sizes are not the same as those indicated on the drawing
- * Diese Abmessungen sind nicht also diese in der Zeichnung reproduziert
- * Dimensions différentes que celles du schéma
- * Dimensión diferente a la del esquema

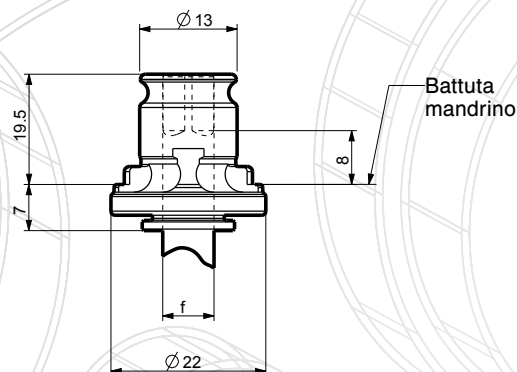

Modello 13/10 Norma ISO
Model 13/10 ISO Standard
Modell 13/10 Norm ISO
Modèle 13/10 Norme ISO
Modelo 13/10 Estándar ISO

CODICE CODE BESTELL NR CODE CÓDIGO	Maschio - Tap Bohrer Taraud - Macho	
	f	□
13/10 28224	2,8	2,24
13/10 31525	3,15	2,5
13/10 0044	4	3,15
13/10 54	5	4
13/10 635	6,3	5

19/11= M3-M12

Modello 19/11 Norma DIN
 Model 19/11 DIN Standard
 Modell 19/11 Norm DIN
 Modèle 19/11 Norme DIN
 Modelo 19/11 Estándar DIN

CODICE CODE BESTELL NR CODE CÓDIGO	Maschio - Tap Bohrer Taraud - Macho		
	f	□	DIN
19/11 2821	2,8	2,1	371
19/11 3527*	3,5	2,7	371
19/11 4534*	4,5	3,4	371
19/11 43	4	3	371
19/11 5543	5,5	4,3	376
19/11 649*	6	4,9	371
19/11 755	7	5,5	376
19/11 862*	8	6,2	371
19/11 97*	9	7	376
19/11 108*	10	8	371
19/11 119	11	9	376

* **Misure consigliate.**
 * *Mainly used sizes.*
 * *Gängige Abmessungen.*
 * *Dimensions conseillées.*
 * *Principales medidas utilizadas.*

Modello 19/11 Norma ANSI
 Model 19/11 ANSI Standard
 Modell 19/11 Norm ANSI
 Modèle 19/11 Norme ANSI
 Modelo 19/11 Estándar ANSI

CODICE CODE BESTELL NR CODE CÓDIGO	Maschio - Tap Bohrer Taraud - Macho	
	f	□
19/11 4036	3,58	2,79
19/11 4039	4,06	3,18
19/11 4041	4,27	3,33
19/11 4047	4,88	3,78
19/11 4048	4,93	3,86
19/11 4054	5,59	4,19
19/11 4063	6,48	4,85
19/11 4079	8,08	6,05
19/11 4095	9,68	7,26
19/11 4097	11,11	8,33
19/11 4098	7,94	5,94
19/11 4111	8,2	6,15
19/11 4127	9,32	6,99
19/11 4142	10,9	8,18

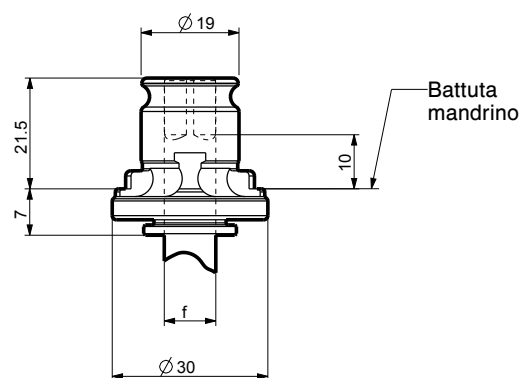

Modello 19/11 Norma JIS
 Model 19/11 JIS Standard
 Modell 19/11 Norm JIS
 Modèle 19/11 Norme JIS
 Modelo 19/11 Estándar JIS

CODICE CODE BESTELL NR CODE CÓDIGO	Maschio - Tap Bohrer Taraud - Macho	
	f	□
19/11 432	4	3,2
19/11 5545	5,5	4,5
19/11 54	5	4
19/11 2064	6	4,5
19/11 2083	6,2	5
19/11 2122	8,5	6,5
19/11 1058	10,5	8

Modello 19/11 Norma ISO
 Model 19/11 ISO Standard
 Modell 19/11 Norm ISO
 Modèle 19/11 Norme ISO
 Modelo 19/11 Estándar ISO

CODICE CODE BESTELL NR CODE CÓDIGO	Maschio - Tap Bohrer Taraud - Macho	
	f	□
19/11 31525	3,15	2,5
19/11 0044	4	3,15
19/11 0046	4,5	3,55
19/11 54	5	4
19/11 635	6,3	5
19/11 0082	8	6,3
19/11 0121	9	7,1
19/11 0144	11,2	9

31/12= M6-M20

Modello 31/12 Norma DIN
 Model 31/12 DIN Standard
 Modell 31/12 Norm DIN
 Modèle 31/12 Norme DIN
 Modelo 31/12 Estándar DIN

CODICE CODE BESTELL NR CODE CÓDIGO	Maschio - Tap Bohrer Taraud - Macho		
	f	□	DIN
31/12 649*	6	4.9	371
31/12 755	7	5.5	376
31/12 862*	8	6.2	371
31/12 97*	9	7	376
31/12 108*	10	8	371
31/12 119*	11	9	376
31/12 129*	12	9	376
31/12 1411*	14	11	376
31/12 1612*	16	12	376
31/12 18145	18	14.5	376

Modello 31/12 Norma ANSI
 Model 31/12 ANSI Standard
 Modell 31/12 Norm ANSI
 Modèle 31/12 Norme ANSI
 Modelo 31/12 Estándar ANSI

CODICE CODE BESTELL NR CODE CÓDIGO	Maschio - Tap Bohrer Taraud - Macho	
	f	□
31/12 4079	8,08	6,05
31/12 4095	9,68	7,26
31/12 4111	8,2	6,15
31/12 4127	9,32	6,99
Δ 31/12 4131C	14,27	10,69
31/12 4142	10,9	8,18
31/12 4158	12,19	9,14
Δ 31/12 4166C	17,78	13,49
31/12 4174	13,77	10,31
Δ 31/12 4190C	14,99	11,23
Δ 31/12 4206C	16,56	12,42
Δ 31/12 4209C	17,46	13,08
Δ 31/12 4222C	17,7	13,28

Δ Per maschi di tipo corto.

Δ For taps short type.

Δ Für Gewindebohrer kurzer Ausführung.

Δ Pour tarauds type court.

Δ Para macho tipo corto.

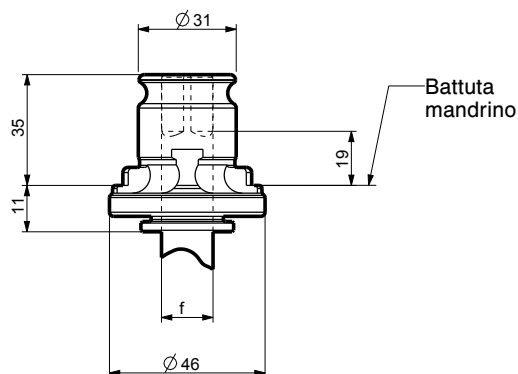

Modello 31/12 Norma ISO
 Model 31/12 ISO Standard
 Modell 31/12 Norm ISO
 Modèle 31/12 Norme ISO
 Modelo 31/12 Estándar ISO

CODICE CODE BESTELL NR CODE CÓDIGO	Maschio - Tap Bohrer Taraud - Macho	
	f	□
31/12 635	6,3	5
31/12 755	7	5,5
31/12 0082	8	6,3
31/12 0121	9	7,1
31/12 1058	10,5	8
31/12 1129	11,2	9
31/12 12510	12,5	10
31/12 14112	14	11,2
31/12 16125	16	12,5
31/12 1814	18	14

48/13= M14-M33

Modello 48/13 Norma DIN
 Model 48/13 DIN Standard
 Modell 48/13 Norm DIN
 Modèle 48/13 Norme DIN
 Modelo 48/13 Estándar DIN

CODICE CODE BESTELL NR CODE CÓDIGO	Maschio - Tap Bohrer Taraud - Macho		
	f	□	DIN
48/13 119	11	9	376
48/13 129	12	9	376
48/13 1411	14	11	376
48/13 1612	16	12	376
48/13 18145	18	14,5	376
48/13 2016	20	16	376
48/13 2218	22	18	376
48/13 2520	25	20	376
48/13 2822	28	22	376

Modello 48/13 Norma ISO
 Model 48/13 ISO Standard
 Modell 48/13 Norm ISO
 Modèle 48/13 Norme ISO
 Modelo 48/13 Estándar ISO

CODICE CODE BESTELL NR CODE CÓDIGO	Maschio - Tap Bohrer Taraud - Macho	
	f	□
48/13 1129	11,2	9
48/13 12510	12,5	10
48/13 14112	14	11,2
48/13 16125	16	12,5
48/13 1814	18	14
48/13 22418	22,4	18

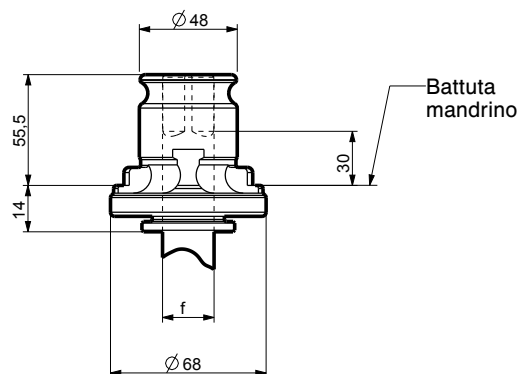

Modello 48/13 Norma ANSI
 Model 48/13 ANSI Standard
 Modell 48/13 Norm ANSI
 Modèle 48/13 Norme ANSI
 Modelo 48/13 Estándar ANSI

CODICE CODE BESTELL NR CODE CÓDIGO	Maschio - Tap - Bohrer Taraud - Macho		
	Filetto Thread Gewinde Filet Rosca	f	□
48/13 4127	1/2"	9,32	6,99
48/13 4142	9/16"	10,9	8,18
48/13 4158	5/8"	12,19	9,14
Δ 48/13 4166C	3/8" NPT	17,78	13,49
48/13 4174	11/16"	13,77	10,31
48/13 4190	3/4"	14,99	11,23
48/13 4206	13/16"	16,56	12,42
Δ 48/13 4209C	1/2" NPT	17,46	13,08
48/13 4222	7/8"	17,7	13,28
48/13 4238	15/16"	19,3	14,48
48/13 4254	1"	20,32	15,24
Δ 48/13 4264C	3/4" NPT	23,01	17,25
48/13 4286	1-1/8"	22,76	17,07
48/13 4317	1-1/4"	25,93	19,46
Δ 48/13 4332C	1" NPT	28,57	21,41
48/13 4349	1-3/8" UNF	28,14	21,11

Δ Per maschi di tipo corto.

Δ For taps short type.

Δ Für Gewindebohrer kurzer Ausführung.

Δ Pour tarauds type court.

Δ Para macho tipo corto.

60/14= M22-M48

Modello 60/14 Norma DIN Model 60/14 DIN Standard Modell 60/14 Norm DIN Modèle 60/14 Norme DIN Modelo 60/14 Estándar DIN			
CODICE CODE BESTELL NR CODE CÓDIGO	Maschio - Tap Bohrer Taraud - Macho		
	f	□	DIN
60/14 18145	18	14,5	376
60/14 2016	20	16	376
60/14 2218	22	18	376
60/14 2520	25	20	376
60/14 2822	28	22	376
60/14 3224	32	24	376
60/14 3629	36	29	376

Modello 60/14 Norma ANSI Model 60/14 ANSI Standard Modell 60/14 Norm ANSI Modèle 60/14 Norme ANSI Modelo 60/14 Estándar ANSI			
CODICE CODE BESTELL NR CODE CÓDIGO	Maschio - Tap Bohrer Taraud - Macho		
	Filetto Thread Gewinde Filet Rosca	f	□
Δ 60/14 4381C	1-1/2"	31,32	23,5
Δ 60/14 4412C	1-5/8"	33,15	24,87
Δ 60/14 4419C	1-1/4" NPT	33,34	24,99
Δ 60/14 4444C	1-3/4"	36,32	27,23
Δ 60/14 4476C	1-7/8"	38,58	28,93
Δ 60/14 4478C	1-1/2" NPT	38,1	28,57

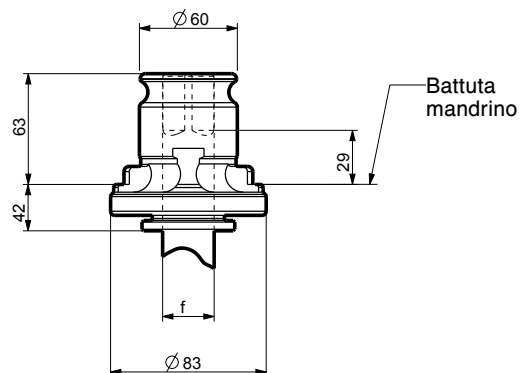

Δ Per maschi di tipo corto.
 Δ For taps short type.
 Δ Für Gewindebohrer kurzer Ausführung.
 Δ Pour tarauds type court.
 Δ Para macho tipo corto.

BUSSOLE PER MASCHIARE SENZA FRIZIONE REGISTRABILE CON FISSAGGIO MASCHIO CON GRANI ESTERNI



BUSH FOR TAPPING WITHOUT SAFETY FRICTION CLUTCH TAP FIXED WITH EXTERNAL SCREWS
SCHNELLWECHSELEINSÄTZE OHNE SICHERHEITSKUPPLUNG GEWINDEBOHRER BEFESTIGUNG MIT SCHRAUBEN
DOUILLE PORTE TARAUD SANS EMBRAYAGE REGLABLE ET SERRAGE DU TARAUD AVEC DES VIS
CASQUILLO PARA ROSCADO SIN EMBRAGUE DE FRICCIÓN DE SEGURIDAD MACHO FIJADO CON TORNILLOS EXTERNOS

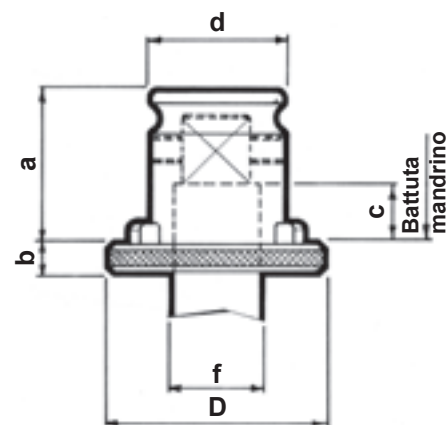

Modello 19/11 G - Model 19/11 G - Modell 19/11 G - Modèle 19/11 G - Modelo 19/11 G							
CODICE CODE BESTELL NR CODE CÓDIGO	d	D	a	b	c	Maschio - Tap Bohrer Taraud - Macho	
						f	□
19/11G 129	19	30	21,5	6	8	12	9

Modello 31/12 G - Model 31/12 G - Modell 31/12 G - Modèle 31/12 G - Modelo 31/12 G							
CODICE CODE BESTELL NR CODE CÓDIGO	d	D	a	b	c	Maschio - Tap Bohrer Taraud - Macho	
						f	□
31/12G 2016	31	46	35	8,5	14	20	16
31/12G 2218	31	46	35	8,5	14	22	18

Modello 48/13 G - Model 48/13 G - Modell 48/13 G - Modèle 48/13 G - Modelo 48/13 G							
CODICE CODE BESTELL NR CODE CÓDIGO	d	D	a	b	c	Maschio - Tap Bohrer Taraud - Macho	
						f	□
48/13G 3224	48	68	55,5	9	28	32	24
48/13G 3629	48	68	55,5	9	28	36	29

Modello 60/14 G - Model 60/14 G - Modell 60/14 G - Modèle 60/14 G - Modelo 60/14 G							
CODICE CODE BESTELL NR CODE CÓDIGO	d	D	a	b	c	Maschio - Tap Bohrer Taraud - Macho	
						f	□
60/14G 0521	60	83	63	33	31	40	32
60/14G 0561	60	83	63	33	31	45	35
60/14G 4508	60	83	63	33	31	41,76	31,32

Per lavorazioni leggere
Suitable for light machining
Für Leichtmetallbearbeitung
Apte pour usinage léger

BUSSOLE MODULARI PROLUNGATE PER MASCHIARE SENZA FRIZIONE REGISTRABILE

EXTENDED BUSH FOR TAPPING WITHOUT SAFETY FRICTION CLUTCH

SCHNELLWECHSELEINSÄTZE OHNE SICHERHEITSKUPPLUNG LANGE AUSFÜHRUNG

DOUILLE PORTE TARAUD MODULAIRE PROLONGÉE SANS EMBRAYAGE REGLABLE

CASQUILLO PARA ROSCADO SIN EMBRAGUE DE FRICCIÓN DE SEGURIDAD EXTENDIDO

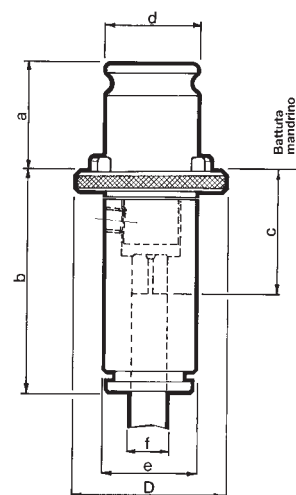

Modello 19/11 P - Model 19/11 P - Modell 19/11 P - Modèle 19/11 P - Modelo 19/11 P

CODICE CODE BESTELL NR CODE CÓDIGO	Bussola + Terminale Bush + Terminal Einsatz + Terminal Douille + Terminal Casquillo + Terminal	Dimensioni - Dimensions Abmessungen Dimensions - Dimensión						Maschio Tap Bohrer Taraud Macho	
		d	D	a	b	c	e	f	□
19/11P 3527 =	45146 + 42147/0030	19	30	21.5	52	33	23	3.5	2.7
19/11P 4534 =	45146 + 42147/0040	19	30	21.5	52	33	23	4.5	3.4
19/11P 649 =	45146 + 42147/0050	19	30	21.5	52	33	23	6	4.9
19/11P 755 =	45146 + 42147/0101	19	30	21.5	52	33	23	7	5.5
19/11P 862 =	45146 + 42147/0080	19	30	21.5	52	33	23	8	6.2
19/11P 97 =	45146 + 42147/0120	19	30	21.5	52	33	23	9	7
19/11P 108 =	45146 + 42147/0100	19	30	21.5	52	33	23	10	8

Modello 31/12 P - Model 31/12 P - Modell 31/12 P - Modèle 31/12 P - Modelo 31/12 P

CODICE CODE BESTELL NR CODE CÓDIGO	Bussola + Terminale Bush + Terminal Einsatz + Terminal Douille + Terminal Casquillo + Terminal	Dimensioni Dimensions Abmessungen Dimensions Dimensión						Maschio Tap Bohrer Taraud Macho	
		d	D	a	b	c	e	f	□
31/12P 649 =	45246 + 42247/0060	31	46	35	74	44	34,5	6	4.9
31/12P 755 =	45246 + 42247/0101	31	46	35	74	44	34,5	7	5.5
31/12P 862 =	45246 + 42247/0080	31	46	35	74	44	34,5	8	6.2
31/12P 97 =	45246 + 42247/0120	31	46	35	74	44	34,5	9	7
31/12P 108 =	45246 + 42247/0100	31	46	35	74	44	34,5	10	8
31/12P 119 =	45246 + 42247/0140	31	46	35	74	44	34,5	11	9
31/12P 129 =	45246 + 42247/0160	31	46	35	74	44	34,5	12	9
31/12P 1411 =	45246 + 42247/0180	31	46	35	74	44	34,5	14	11
31/12P 1612 =	45246 + 42247/0200	31	46	35	74	44	34,5	16	12

BUSSOLE MODULARI PROLUNGATE PER MASCHIARE SENZA FRIZIONE REGISTRABILE



EXTENDED BUSH FOR TAPPING WITHOUT SAFETY FRICTION CLUTCH
 SCHNELLWECHSELEINSÄTZE OHNE SICHERHEITSKUPPLUNG LANGE AUSFUHRUNG
 DOUILLE PORTE TARAUD MODULAIRE PROLONGÉE SANS EMBRAYAGE REGLABLE
 CASQUILLO PARA ROSCADO SIN EMBRAGUE DE FRICCIÓN DE SEGURIDAD EXTENDIDO

Modello 48/13 P - Model 48/13 P - Modell 48/13 P - Modèl 48/13 P - Modelo 48/13 P

CODICE CODE BESTELL NR CODE CÓDIGO	Bussola + Terminale Bush + Terminal Einsatz + Terminal Douille + Terminal Casquillo + Terminal	Dimensioni Dimensions Abmessungen Dimensions Dimensión						Maschio Tap Bohrer Taraud Macho	
		d	D	a	b	c	e	f	□
48/13P 119 =	45346 + 42347/0140	48	68	55,5	100	57	48	11	9
48/13P 129 =	45346 + 42347/0160	48	68	55,5	100	57	48	12	9
48/13P 1411 =	45346 + 42347/0180	48	68	55,5	100	57	48	14	11
48/13P 1612 =	45346 + 42347/0200	48	68	55,5	100	57	48	16	12
48/13P 18145 =	45346 + 42347/0220	48	68	55,5	100	57	48	18	14,5
48/13P 2016 =	45346 + 42347/0270	48	68	55,5	100	57	48	20	16
48/13P 2218 =	45346 + 42347/0300	48	68	55,5	100	57	48	22	18
48/13P 2520 =	45346 + 42347/0330	48	68	55,5	100	57	48	25	20

PROLUNGHE

EXTENSION
 VERLÄNGERUNGEN
 EXTENSION
 EXTENSIÓN

CODICE CODE BESTELL NR CODE CÓDIGO	Per Bussola For Bush Einsatz Pour douille Para casquillo	D	L
42150/25	19/1P-19/11P	23	25
42150/50	19/1P-19/11P	23	50
42250/50	31/2P-31/12P	35	50
42250/100	31/2P-31/12P	35	100
42350/50	48/3P-48/13P	48	50
42350/100	48/3P-48/13P	48	100



ESEMPIO DI COMPOSIZIONE PER BUSSOLE PROLUNGATE

EXAMPLE TO USE EXTENDED BUSHES

KOMBINATION VON LANGENSCHNELLWECHSELEINSÄTZE UND VERLÄNGERUNGEN

EXEMPLE DE COMPOSITION DE DOUILLE MODULAIRE PROLONGÉE

EJEMPLO DE USO DE CASQUILLOS EXTENDIDOS

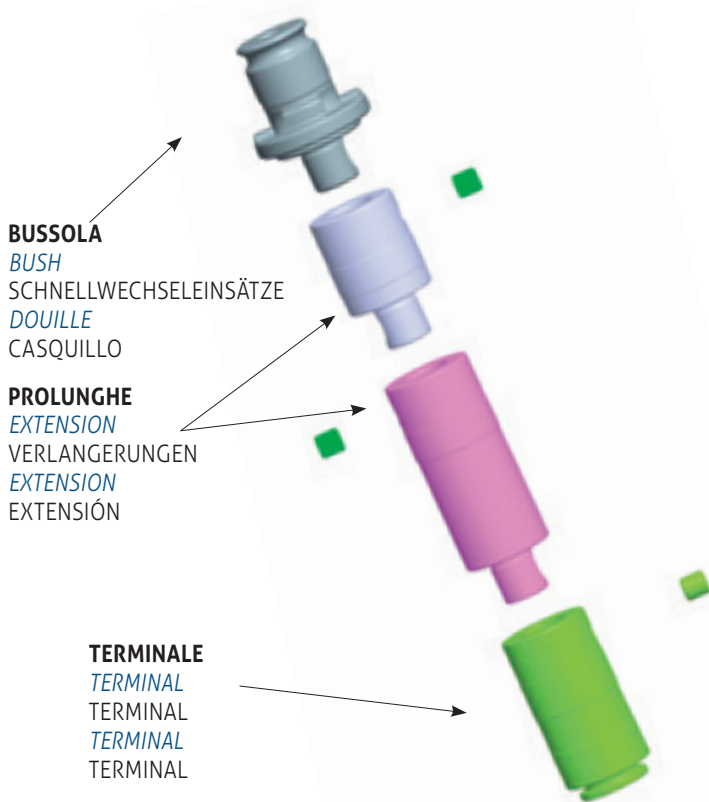

In questa pagina descriviamo un esempio pratico di come si possono comporre le bussole modulari prolungate 19/1P - 19/11P - 31/2P - 31/12P - 48/3P - 48/13P descritte nelle tabelle delle pagine precedenti.

Per esempio:

inserendo in una bussola con codice 19/1P-335 una prolunga cod. 42150/25 di lunghezza 25 mm. ed una prolunga cod. 42150/50 di lunghezza 50 mm si ottiene una lunghezza utile "B" di 145 mm. ($70+25+50=145$). Quindi dall'esempio succitato si può dedurre che è possibile ottenere per le bussole modulari prolungate una lunghezza minima di 70 mm, incrementabile con passi di 25 mm.

On this page we explain a practice example for our extended bushes 19/1P - 19/11P - 31/2P - 31/12P - 48/3P - 48/13P.

For example:

as the length of 19/1P is 70 mm, if you join an extension 42150/25 (L=25 mm) and an extension 42150/50 (L=50 mm) you can obtain the total length "B" of mm 145. Extension available of 25 mm.

Auf dieser Seite zeigen wir Ihnen ein praktisches Beispiel für unsere langen Schnellwechseleinsätze 19/1P - 19/11P - 31/2P - 31/12P - 48/3P - 48/13P auf.

Beispiel:

Die Auskraglänge des Schnellwechseleinsatzes 19/1P ist 70 mm. Wenn Sie eine Verlängerung 42150/25 (L=25 mm) und eine Verlängerung 42150/50 (L=50 mm) einbringen erhalten Sie als Gesamtauskraglänge „B“ 145 mm total. Weitere 25 mm Verlängerungen verfügbar.

Dans cette page on vous propose un exemple pratique de composition de douille modulaire prolongée 19/1P - 19/11P - 31/2P - 31/12P - 48/3P - 48/13P décrites dans les pages précédentes :

Par exemple :

Dans une douille code 19/1P 335 on met une extension code 42150/25 avec une longueur de 25 mm. plus une extension code 42150/50 avec une longueur de 50 mm. et on obtient une longueur totale 'B' de 145 mm. ($70+25+50=145$).

Donc sur la base de cet exemple, il est possible déduire que l'on peut obtenir une douille modulaire prolongée avec une longueur minimum de 70 mm, réalisée avec des multiples de 25 mm.

En esta página le mostramos un ejemplo práctico para nuestros casquillos extendidos 19/1P - 19/11P - 31/2P - 31/12P - 48/3P - 48/13P.

Por ejemplo:

Si a la longitud de 19/1P es 70 mm., se le une una extensión 42150/50 (L=50 mm.) se puede obtener una longitud total «B» de 145 mm.. La longitud se puede aumentar de 25 a 25 mm.

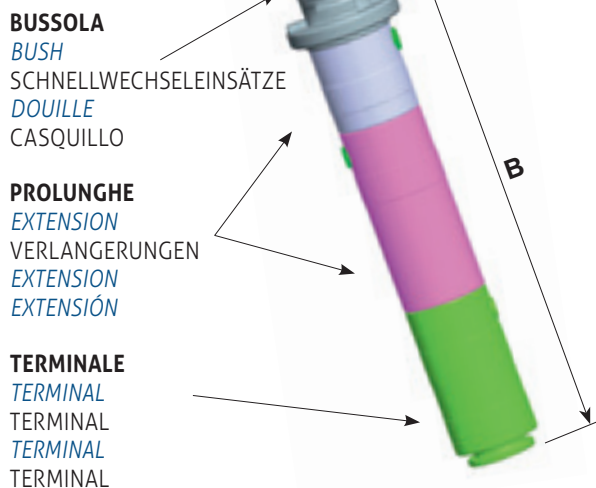

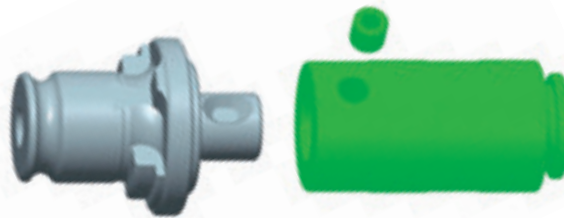
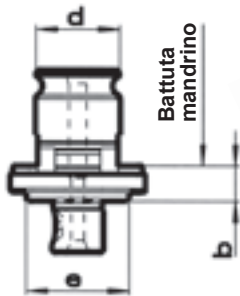

MOD. 45146
Bussola
Bush
Einsatz
Douille
Casquillo

d	19
b	8
e	23

CODICE CODE BESTELL NR CODE CÓDIGO	Filetto Thread Gewinde Filet Rosca
45146	M3-M12

MOD. 42147
Terminale
Terminal
Terminal
Terminal
Terminal

e	23
L	44
L1	25

CODICE CODE BESTELL NR CODE CÓDIGO	Filetto Thread Gewinde Filet Rosca	f	□
42147/0030	M3	3.5	2.7
42147/0040	M4	4.5	3.4
42147/0050	M5	6	4.9
42147/0050	M6	6	4.9
42147/0080	M8	8	6.2
42147/0101	M10	7	5.5
42147/0100	M10	10	8
42147/0120	M12	9	7

MOD.42247
Terminale
Terminal
Terminal
Terminal
Terminal

e	34.5
L	63
L1	33

CODICE CODE BESTELL NR CODE CÓDIGO	Filetto Thread Gewinde Filet Rosca	f	□
42247/0060	M6	6	4.9
42247/0080	M8	8	6.2
42247/0101	M10	7	5.5
42247/0100	M10	10	8
42247/0120	M12	9	7
42247/0140	M14	11	9
42247/0160	M16	12	9
42247/0180	M18	14	11
42247/0200	M20	16	12

MOD. 45246
Bussola
Bush
Einsatz
Douille
Casquillo

d	31
b	11
e	36

CODICE CODE BESTELL NR CODE CÓDIGO	Filetto Thread Gewinde Filet Rosca
45246	M6-M20



MOD. 45346 Bussola Bush Einsatz Douille Casquillo	
d	48
b	14
e	48
CODICE CODE BESTELL NR CODE CÓDIGO	Filetto Thread Gewinde Filet Rosca
45346	M14-M33

MOD. 42347 Terminale Terminal Terminal Terminal Terminal			
e	48		
L	86		
L1	45		
CODICE CODE BESTELL NR CODE CÓDIGO	Filetto Thread Gewinde Filet Rosca	f	□
42347/0140	M14	11	9
42347/0160	M16	12	9
42347/0180	M18	14	11
42347/0200	M20	16	12
42347/0220	M22	18	14.5
42347/0220	M24	18	14.5
42347/0270	M27	20	16
42347/0300	M30	22	18
42347/0330	M33	25	20

BUSSOLE PORTA PINZA PER PINZE A GRANDE ESPANSIONE DIN 6499

BUSH FOR DIN 6499 FIXING COLLETS

SCHNELLWECHSELEINSÄTZE FÜR SPANNZANGEN DIN 6499

DOUILLES PORTE-PINCE POUR PINCES DIN 6499

CASQUILLO PORTAPINZAS PARA PINZAS DIN 6499

CODICE CODE BESTELL NR CODE CÓDIGO	d	Per pinze DIN 6499 For DIN 6499 collets Spannzangen Pour Pince DIN6499 Para pinzas DIN 6499	f	L	C	D
19/11 ER16	19	ER16	1- 10	29,5	4,5	28
31/12 ER25	31	ER25	2 - 16	38,5	4,5	42

Forniti con ghiera esagonale

Supplied with hex. Nut

Lieferbar zusammen mit Hexagonmutter

Fourni avec bague hexagonale

Entregado con tuerca hexagonal

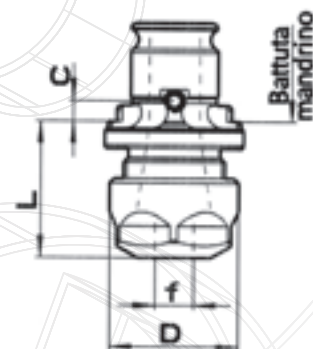

BUSSOLE PER MASCHIARE CON E SENZA FRIZIONE REGISTRABILE CON PASSAGGIO LUBRIFICANTE SUL FIANCO DELL'UTENSILE

BUSH FOR TAPPING WITH AND WITHOUT ADJUSTABLE CLUTCH FOR TAPPING WITH COOLANT FLOW ON THE TOOL SIDE

SCHNELLWECHSELEINSÄTZE MIT UND OHNE SICHERHEITSKUPPLUNG MIT KÜHLMITTELZUFUHR SEITLICH AM GEWINDEBOHRERSCHAFT

DOUILLES PORTE TARAUD AVEC ET SANS EMBRAYAGE REGLABLE AVEC PASSAGE DU LUBRIFIANT SUR LES COTES DE L'OUTIL

CASQUILLO PARA ROSCADO CON Y SIN EMBRAGUE AJUSTABLE CON REFRIGERACIÓN INTERIOR LATERAL DE HERRAMIENTA

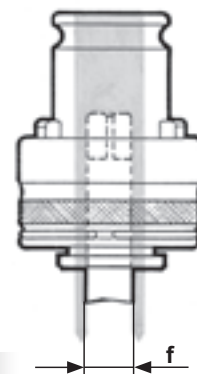

CODICE CODE BESTELL NR CODE CÓDIGO	Capacità Maschiatura Tap capacity Bereich Capacité de taraudage Capacidad macho	Maschio Tap Bohrer Taraud Macho f
19/1L	M4-M12	4,5 - 10
31/2L	M6-M20	6 - 16
48/3L	M14-M33	11 - 25

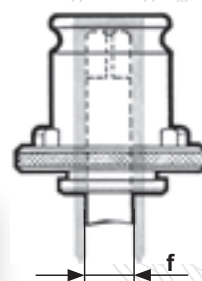

CODICE CODE BESTELL NR CODE CÓDIGO	Capacità Maschiatura Tap capacity Bereich Capacité de taraudage Capacidad macho	Maschio Tap Bohrer Taraud Macho f
19/11L	M4-M12	4,5 - 10
31/12L	M6-M20	6 - 16
48/13L	M14-M33	11 - 25

Disponibili con e senza frizione registrabile.

Available with and without safety friction clutch.

Lieferbar mit und ohne sicherheitskupplung.

Disponible avec ou sans embrayage réglable.

Disponible con y sin embrague de fricción de seguridad.

BUSSOLE PORTA FILIERA SENZA FRIZIONE REGISTRABILE

BUSH FOR SCREW PLATE WITHOUT SAFETY FRICTION CLUTCH
 SCHNELLWECHSELEINSÄTZE OHNE SICHERHEITSKUPPLUNG FÜR SCHNEIDEISEN
 DOUILLES PORTE-FILIERE SANS EMBRAYAGE
 CASQUILLO PORTATERRAJAS SIN EMBRAGUE DE FRICCIÓN DE SEGURIDAD

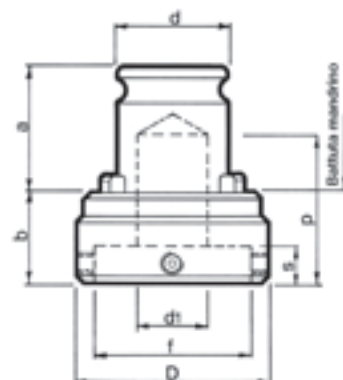

CODICE CODE BESTELL NR CODE CÓDIGO	ATTACCO SHANK AUFNAHMEN ATTACHEMENT MANGO	d	D	a	b	f	s	dl	p
• 19/11F 165	16X5	19	25	21,5	9	16	4,8	12,5	23
• 19/11F 205	20X5		30		9	20	4,8	12,5	23
• 19/11F 207	20X7		30		11	20	6,5	12,5	25
• 19/11F 259	25X9		35		14	25	8,5	12,5	28
• 19/11F 3011	30X11		40		16	30	10	12,5	30
• 19/11F 3810	38X10		48		15	38	9	14,2	29
• 19/11F 3814	38X14		48		19	38	13	14,2	33
• 31/12F 205	20X5	31	30	35	22	20	4,8	15	57
• 31/12F 207	20X7		30		22	20	6,5	15	57
• 31/12F 259	25X9		35		22	25	8,5	15	57
• 31/12F 3011	30X11		40		22	30	10	22	57
• 31/12F 3810	38X10		48		22	38	9	22	57
• 31/12F 3814	38X14		48		25	38	13	22	60
• 31/12F 4514	45X14		57		29	45	13	22	64
• 31/12F 4518	45X18		57		29	45	17	22	64

- Disponibile solo su richiesta
Available only on demand
 Verfügbar nur auf Anfrage
Disponible seulement sur demande
 Disponibles bajo petición

BUSSOLE DI RIDUZIONE

REDUCTION
REDUZIERUNGEN
DOUILLE DE REDUCTION
REDUCCIÓN

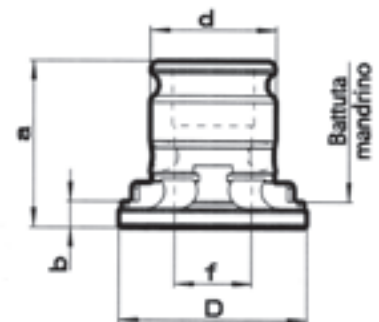

CODICE CODE BESTELL NR CODE CÓDIGO	d	f	D	a	b
19/11R13	19	13	30	21,5	6
31/12R19	31	19	46	35	8,5
48/13R19	48	19	68	55,5	7
48/13R31	48	31	68	55,5	7

